

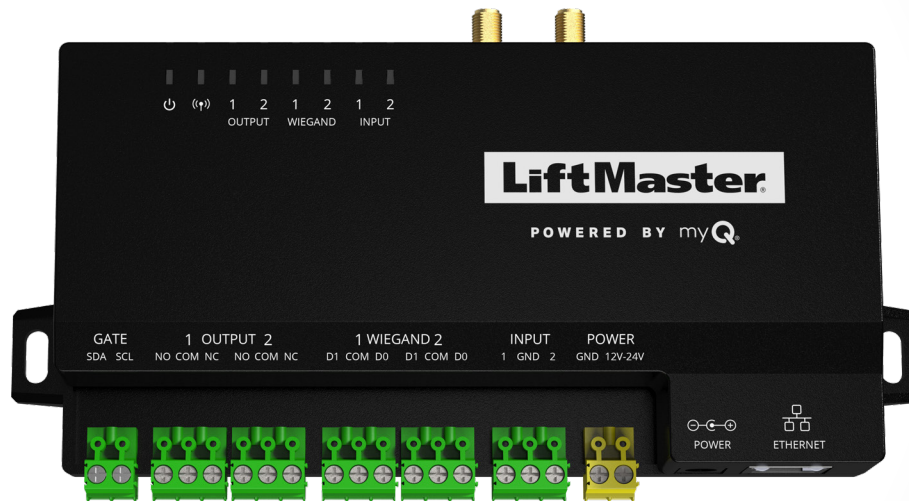

Smart Access Hub

INSTALLATION MANUAL

Model CAPAC



Safety

Safety Symbol and Signal Word Review

When you see these Safety Symbols and Signal Words on the following pages, they will alert you to the possibility of serious injury or death if you do not comply with the warnings that accompany them. The hazard may come from something mechanical or from electric shock. Read the warnings carefully.

When you see this Signal Word on the following pages, it will alert you to the possibility of damage to your property or product if you do not comply with the cautionary statements that accompany it. Read them carefully.

NOTE: Complete the Pre-Install instructions before going on site.

 **WARNING**

MECHANICAL

 **WARNING**

ELECTRICAL

 **CAUTION**

  **WARNING**

- To reduce the risk of SEVERE INJURY or DEATH:
- Disconnect power at the fuse box BEFORE proceeding.
 - To AVOID damaging gas, power or other underground utility lines, contact underground utility locating companies BEFORE digging.
 - ALL electrical connections MUST be made by a qualified individual.
 - ALL power and control wiring MUST be run in separate conduit.

- To protect against fire and electrocution:
- Disconnect power BEFORE installing or servicing CAPAC.
 - NEVER connect a keypad/reader or lock to doors without first consulting the applicable fire code.
 - You MUST consult with, and get approval from, local authorities having jurisdiction BEFORE installing locks or devices on ANY doors that may be fire exits.
 - Use of egress push buttons may not be legal. Single action exits may be required.
 - ALWAYS obtain proper permits and approvals in writing BEFORE installing equipment.

 **WARNING:** This product can expose you to chemicals including lead, which are known to the State of California to cause cancer or birth defects or other reproductive harm. For more information go to www.P65Warnings.ca.gov.

INTRODUCTION

Carton Inventory	4
Tools Needed	4
Additional Tools Recommended	4
Overview	5
Electrical Specifications	6
Internet Requirements	7

1 PRE-INSTALL

Setup a myQ® Business™ Account	8
Add CAPAC Device(s) to myQ Business Facility	8

2 NETWORK

Connect Internet	9
Connecting CAPAC to Cellular	10
Diagnostics	12

3 MOUNTING/POWER

Wall Installation	13
External Antenna Installation	13
Connect Power	14

4 ACCESS CONTROL

Gate Access	15
Door Access	16
Door Access - Vestibule	17
Wiegand Output	18
Repair Parts	19
Accessories	19
Legal Disclaimers	19
Warranty	20



myQ® Community Control

myQ® Smart Community Access Technology enables secure monitoring and control of gated community or MDUs access points and other myQ® Smart Community Access devices with a smartphone, tablet or computer.

Alerts can be received as email notifications, ensuring the status of access points.

Carton Inventory

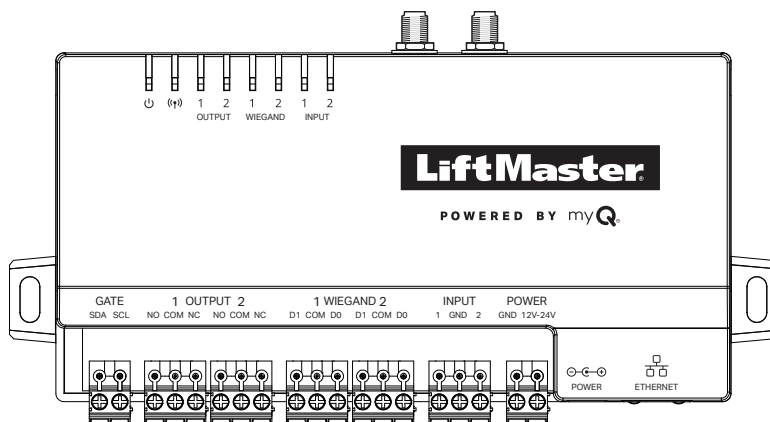

CAPAC Device

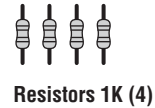

Resistors 1K (4)

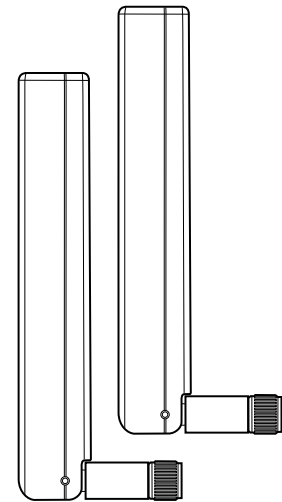

Paddle Antennas (2)

PROVIDED (NOT SHOWN)

- Installation Manual

Tools Needed

- PH2 Phillips Screwdriver
- Precision 1/8" Flat or PH0 Phillips Screwdriver
- 5/16" Nut driver
- Drill/Driver
- 1/8" Drill Bit
- Hammer Drill Bits for Drill/Driver
- RJ45 Crimping Pliers
- Multimeter
- Measuring tape

Additional Tools Recommended

- Network LAN Cable Tester
- Wi-Fi Analyzer App (Smart Phone App)
- Network Analyzer software
- Cellular Analyzer tool

Overview

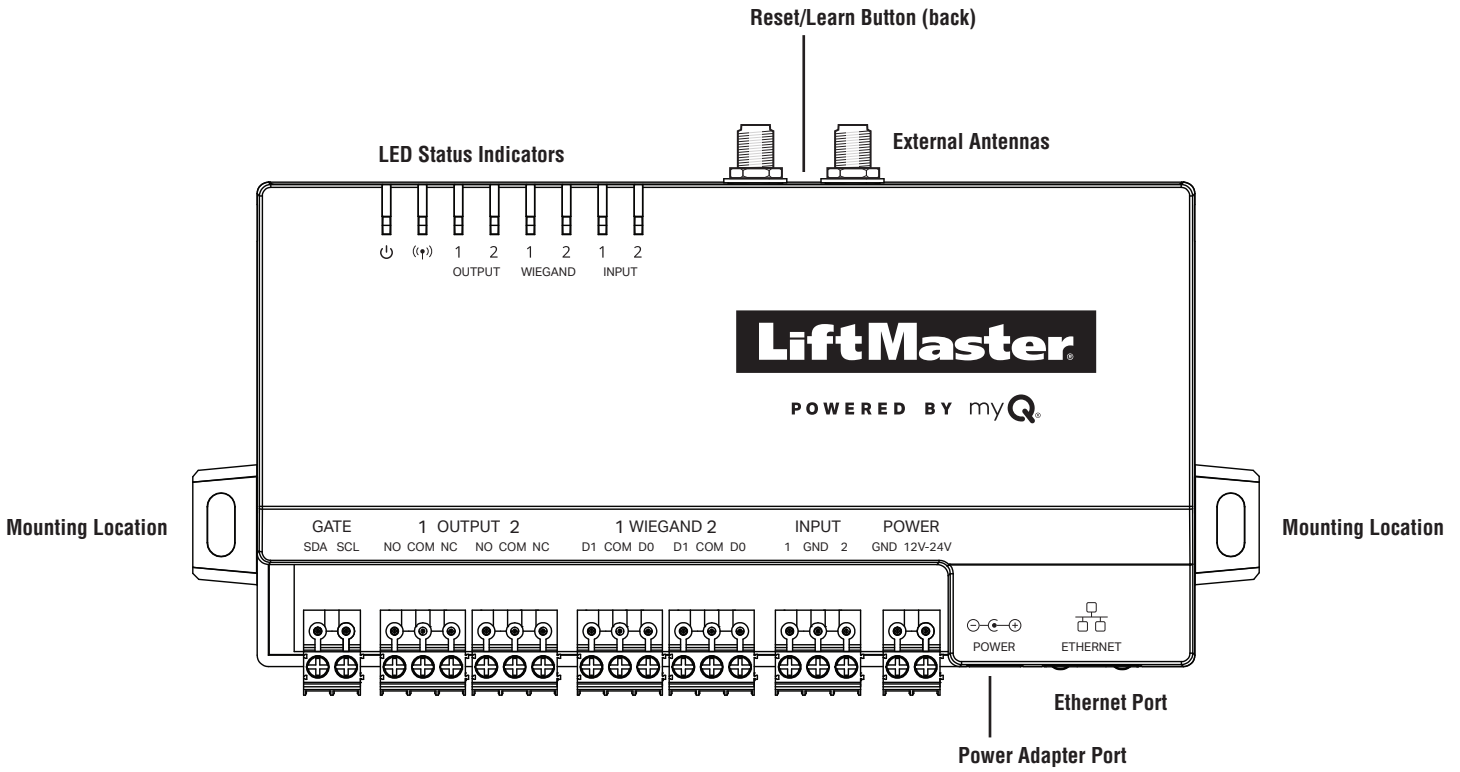

INPUT/OUTPUT	USED FOR
Relay Output 1	Gate Operator, Door Strikes, Maglocks, Lights (For control only. Power to be provided by external power supply), Alarm Shunt
Relay Output 2	
Wiegand Output 1	26-bit, 30-bit, 32-bit, 37-bit
Wiegand Output 2	
Input 1	Closed Door Sensor (Supervised EOL or unsupervised), Closed Limit Gate Sensor (Supervised EOL or unsupervised), Open Limit Gate Sensor (Supervised EOL or unsupervised)
Input 2	

NOTE: For UL installations, only UL 325 Listed gate operators, UL 294 Listed electric door strikes or UL 294 Listed maglocks may be connected to relay output 1 or 2.

NOTE: For UL installations, only a Listed UL 294 access control unit may be connected to Wiegand output 1 or 2.

NOTE: The inputs can be used as a door sensor which will help detect the door ajar. The inputs can also be used for detecting close limit reached and open limit reached.

Electrical Specifications

CAPAC SPECIFICATIONS	
CAPAC Capacity	Resident Capacity 50,000 (cloud only)
Supply Voltage	6-24VDC
Operating Current	0.7A (max at 7.5VDC, 0.2A max at 24VDC)
CAPAC Operating Temperature Range	-29°C to 65°C (-20°F to 149°F)
Enclosure	ABS Plastic
Storage and Shipping Temperature Range	-40°C to 65°C (-40°F to 149°F)
Wiegand Outputs (2)	26-bit, 30-bit, 32-bit, 37-bit
2 Relay Outputs	SPDT, Rated Load - 2A at 30VDC (each)
Network Compatibility	10/100 Ethernet
Wi-Fi® Compatibility	802.11b/g/n
Wi-Fi® Security	WPA2 Personal (AES) and WPA3 Personal
Wi-Fi® Range	Up to 250 feet (76.2 m), Open Air/Line-of-Sight to CAPAC (range will vary depending on obstructions)

Internet Requirements

When selecting a router, use the information below to ensure compatibility.

MODEL: CAPAC - Smart Access Hub

CAPAC can be connected to a router via a wired connection or Wi-Fi. LiftMaster recommends a minimum upload/download speed of 1Mbps for each CAPAC.

NOTE: *This upload speed MUST be met when considering usage of other devices on the network like cameras and computers.*

Keep at least 18 inches (46 cm) between the antennas and any electronic devices (especially anything unshielded or higher voltage like pumps/HVAC/heavy machinery) and away from metal that would block the area around the antenna.

CAPAC IS COMPATIBLE WITH ROUTERS USING THE FOLLOWING Wi-Fi COMMUNICATION PROTOCOLS:

- 802.11b
- 802.11g
- 802.11n @ 2.4 GHz

CAPAC WI-FI SECURITY COMPATIBILITY

- WPA3 Personal
- WPA2 Personal (AES)

ADDITIONAL COMPATIBILITY CONSIDERATIONS:

- If using a Wi-Fi signal strength tool or app, a continuous Wi-Fi signal strength connection of at least -65 dBm (numbers closer to zero are stronger strength) at the CAPAC must be guaranteed to ensure an acceptable connection to the local network.
- Hidden network SSIDs are not supported.
- Wi-Fi networks requiring secondary authentication are not supported (E.g. Hotels and airport Wi-Fi).
- When checking cellular signal strength, we recommend at least two bars or (RSRP > -115 dBm and RSRQ > -19 dBm).
- For Cellular connectivity, a 4G/LTE network is the minimum requirement for optimal performance.

The following services are required for CAPAC to fully function

Setup a myQ® Business™ Account

NOTE: If you have an existing myQ® account, your myQ® Business™ account will have the same password. Go to: account.myq.com and login.

1. If you do not have a myQ® Business™ account, call LiftMaster Customer Care and myQ Business Account Creation at 877-247-6764 to activate a myQ® Business™ account.
Be prepared by reviewing the information required on the [Installation Readiness Survey](#):
2. You will get a welcome email from LiftMaster. Accept the invitation and register or login to your account.
3. Setup the facility, select a CAPAC Device Subscription Plan, add residents and credentials (refer to the available Help in myQ® Business™).
4. Continue with the installation of the CAPAC in this manual.

For Support, call 877-247-6764 or visit <https://support.partner.liftmaster.com/s/community-access-support>

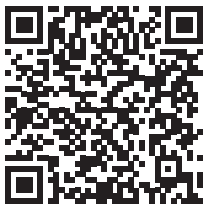

For more information use your smartphone to scan the QR code.

Add CAPAC Device(s) to myQ Business

1. After successfully adding or updating a subscription, click Add Devices from the Subscription Successful! Popup window. Alternatively, you can click on Device Management to get to the next step.
2. Click on the +Add Device button.
3. Select Smart Access Hub.
4. Add the number of devices and number of Access Points and click Next.
5. Under Configure Devices, click on Start for Smart Access Hub.

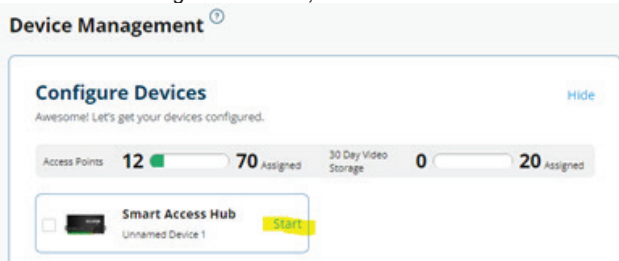

6. Type Controller Number and Controller Name.
7. Click Save.
8. Follow the online instructions to activate cellular and to configure doors/ports.

Connect Internet

The CAPAC can connect to the Internet with a wired Ethernet, with Wi-Fi® (wireless), or with a cellular network. Log into CAPAC Webpage via step 1 below and then configure which of the internet connection methods (Ethernet, Wi-Fi, Cellular) is used via step 2 below.

Step 1

The CAPAC can connect to the Internet with a wired Ethernet, with Wi-Fi® (wireless) or with a cellular network. Log into the CAPAC Wi-Fi to configure which of the methods is used.

1. Press and hold the Reset/Learn button for 5 seconds to reset to factory settings (the connectivity LED will be off).
2. Press and hold the Reset/Learn button for 2 seconds to get to the access point page (the connectivity LED will blink green).
3. On your mobile device, go into Wi-Fi configuration and look for the CAPAC Wi-Fi network. The Wi-Fi network format will be "MyQ-xxx" where xxx is the last three digits of your CAPAC's CP#.
4. If "Internet may not be available" message is received, select "keep Wi-Fi connection".
5. Open web browser (e.g., Edge, Chrome) and enter either setup.myqdevice.com or 192.168.1.1. Note that if you exit the CAPAC MyQ-xxx Wi-Fi network, open a new web browser and enter setup.myqdevice.com or 192.168.1.1 to restart your configuration.
6. Select Start to see the current Internet connection method.

Step 2

Ethernet (DHCP and Static)

The Local Area Network(LAN) port is a 10/100 Ethernet interface with an RJ45 jack for connecting the CAPAC to an Ethernet hub, switch, or router in order for it to gain connectivity to the Internet. Use a straight (i.e. non-crossover) Cat5, Cat5e, or Cat6 cable to connect to a local hub, switch or router. This type of cable is referred to as an Ethernet cable in this manual.

1. Connect an Ethernet cable from the Ethernet hub, switch or router to the Ethernet port of the CAPAC.
2. For DHCP, select Ethernet DHCP and click on "Next" icon.
3. For Static, select Ethernet Static and click on "Next" icon. Then fill in the information and click on "Next" icon.
4. If the green LED next to the blue power LED is not lit or if the phone is still on the "connecting to Internet" screen after 3 minutes, check the connections on CAPAC and Ethernet hub. Resolve and repeat from Step 1.
5. When connected properly, there will be a congratulation message indicating that your device is connected. The green LED next to the blue power LED will be solid on the CAPAC housing.
6. From your mobile device, exit the MyQ-xxx Wi-Fi network.

Wi-Fi® (Wireless)

1. Select Wi-Fi and click on "Next" icon.
2. Select your site's Wi-Fi network.
3. Enter you Wi-Fi network password and then click on "Next" icon.
4. Click "Next" icon again to acknowledge update.
5. Select the status of the LED next to the blue power LED.
6. When connected properly, there will be a congratulation message indicating that your device is connected. The green LED next to the blue power LED will be solid on the CAPAC housing. Follow directions to troubleshoot issue if needed.
7. From your mobile device, exit the MyQ-xxx Wi-Fi network.

Cellular (Wireless)

1. Select Cellular and click on "Next" icon.
2. From myQ® Business™, verify that the cellular service has been enabled for the CAPAC device. Note that this can take up to 15 minutes.
3. When connected properly, there will be a congratulation message indicating that your device is connected. The green LED next to the blue power LED will be solid on the CAPAC housing. Follow directions to troubleshoot issue if needed.
4. From your mobile device, exit the MyQ-xxx Wi-Fi network.

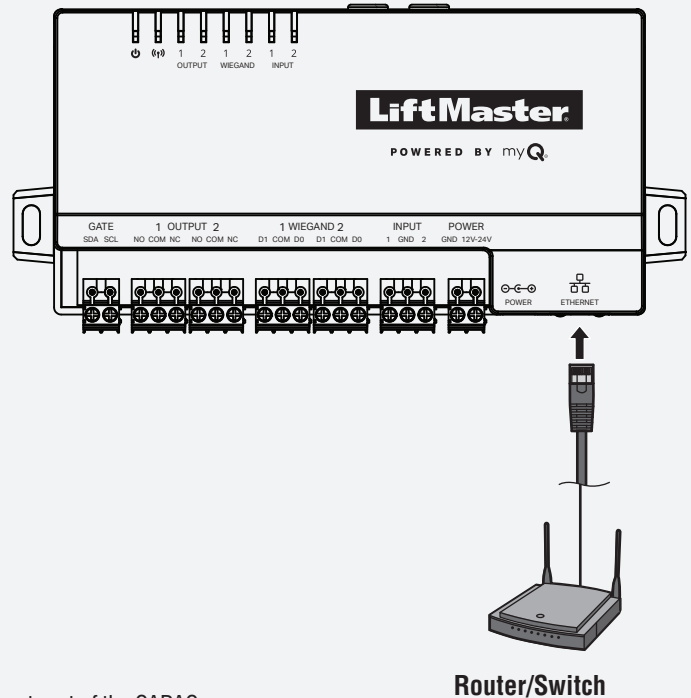

Connecting CAPAC to Cellular

1. On the CAPAC, press and hold the Reset/Learn button for 2 seconds to get to the access point page (the connectivity LED will blink green).
2. On your mobile device, go into the Wi-Fi configuration and look for the CAPAC Wi-Fi network. The Wi-Fi network format will be "MyQ-xxx," where xxx is the last three digits of your CAPAC's CP#. (See Figure 1)
NOTE: If the "Internet may not be available" message displays, click keep Wi-Fi connection.
3. Open a web browser (e.g., Edge, Chrome) and enter either setup.myqdevice.com or 192.168.1.1. (See Figure 2)
NOTE: If you exit the CAPAC MyQ-xxx Wi-Fi network, open a new web browser and enter setup.myqdevice.com or 192.168.1.1 to restart your configuration.
4. To see the current Internet connection method, click Start.
5. From myQ® Business™, verify that the cellular service has been enabled for the CAPAC device. (See Figure 4)
6. Select Cellular and click Next. (See Figure 3)
NOTE: This can take up to 15 minutes.
7. When connected properly, a congratulation message indicates that your device is connected. The LED next to the blue power LED will be solid on the CAPAC housing. Follow directions to troubleshoot issues if needed. (See Figure 5)

NOTE: The color of the LED indicates cellular signal strength. Red indicates fair connectivity, Amber/Orange indicates good connectivity, and Green indicates excellent connectivity.

NOTE: If the CAPAC fails to connect to cellular, ensure the cellular subscription is activated in myQ Business. If subscription is active, see the section in the next page on how resolve cellular connectivity.

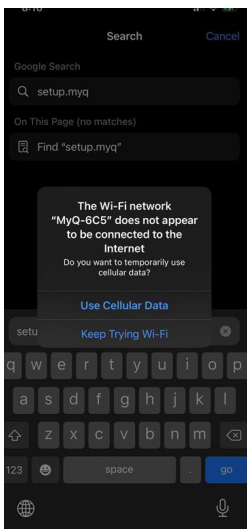
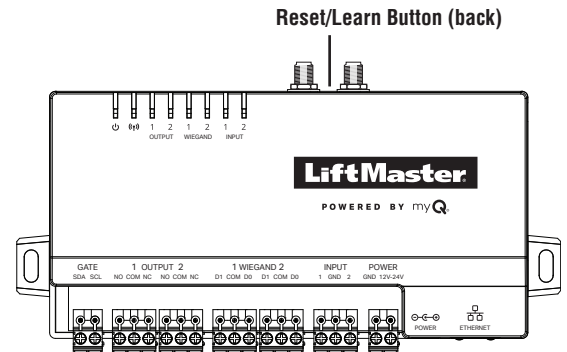

Figure 1

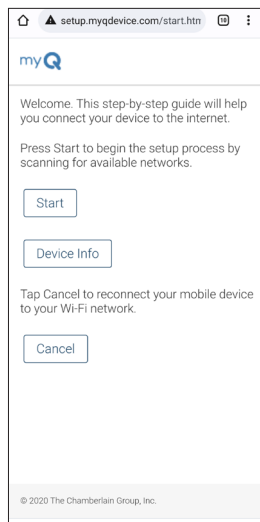

Figure 2

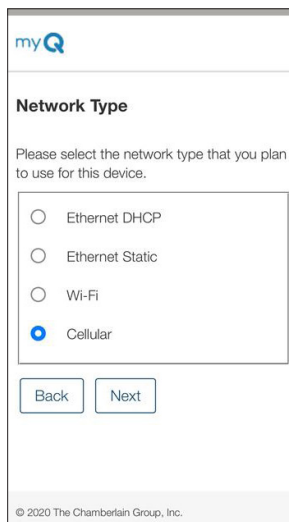

Figure 3

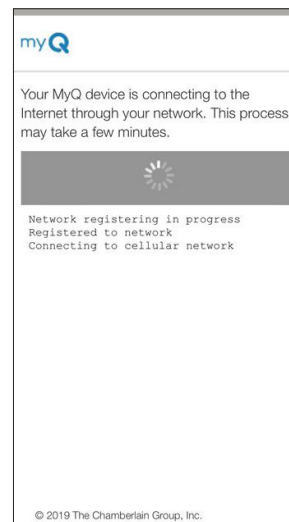

Figure 4

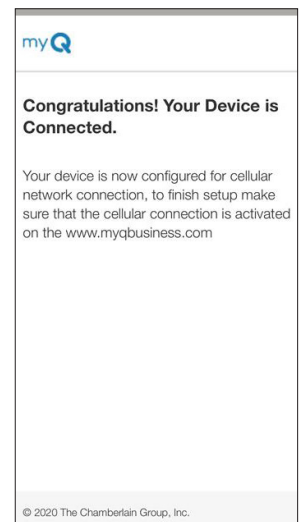

Figure 5

Connecting CAPAC to Cellular (continued)

8. From your mobile device, exit the MyQ-xxx Wi-Fi network.

NOTE: Once your Device is connected, your mobile device automatically disconnects from the MyQ-xxx Wi-Fi network and connects back to your local Wi-Fi network.

9. Go back to your facility on myQbusiness.com to check the device status. You may have to refresh the page to notice changes to connectivity.

NOTE: Be sure to update the firmware and test the relays before continuing to install the CAPAC! When mounting the CAPAC, always consider cellular signal strength.

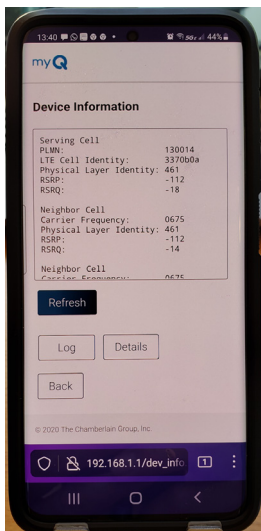

Figure 6



Figure 7

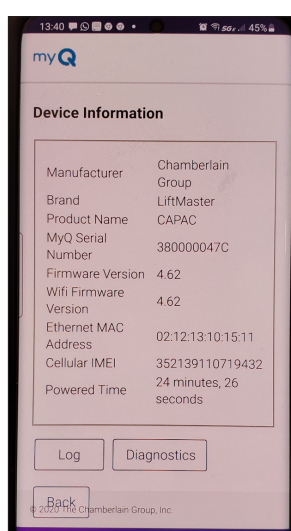

Figure 8

Resolve issues with cellular connectivity

If cellular signal is not optimum, consider relocating the device to achieve better cellular signal strength or adding the optional cellular antenna extension kit (G86LMT).

Reference Signal Received Power (RSRP) – The average power received from a single reference signal.

Reference Signal Received Quality (RSRQ) – Indicates the quality of the received signal.

Cellular Connection				
Use a Cellular Signal Meter or the Diagnostic tab on the CAPAC AP page				
LTE Cellular Using RSRP or RSRQ	RSRP	RSRQ	Are there one or more cellular signals that are good or fair? Yes or No	If No (all cellular signals are poor), move CAPAC and/or use external antenna kit (CELLXKT) to get at least one cellular signal that is good or fair.
Good	≥ -14 dBm	≥ -16 dBm		If all signal sources are still poor after taking these actions, we recommend using Wi-Fi or Ethernet connections
Fair	> -115 dBm	> -19 dBm		
Poor	≤ -115 dBm	≤ -19 dBm		

Diagnostics

((+)) CONNECTIVITY		
	SOLID GREEN	Ethernet/Wi-Fi/Cellular: Connection is established with STRONG signal strength AND device IS myQ Community connected.
	FLASHING GREEN	Ethernet/Wi-Fi/Cellular: Connection IS established with STRONG signal strength AND device IS NOT myQ Community connected.
	SOLID AMBER	Wi-Fi/Cellular: Connection IS established with WEAK signal strength AND device IS myQ Community connected.
	FLASHING AMBER	Wi-Fi/Cellular: Connection IS established with WEAK signal strength AND device IS NOT myQ Community connected.
	SOLID RED	Ethernet/Wi-Fi/Cellular: Connection NOT established OR Wi-Fi/Cellular signal strength is UNUSABLE.
	CYCLING TRI-COLOR	Firmware: Updating
	PULSATING GREEN	Wi-Fi: Provisioning in process, Wi-Fi access point page available.

⏻ POWER		
	SOLID BLUE	Power ON

OUTPUT 1/2		
	SOLID GREEN	Output Activated

WIEGAND 1/2		
	SOLID GREEN	Wiegand Credentials Sent

INPUT 1/2		Supervised	Non-Supervised
	SOLID GREEN	Input NOT Activated	Input NOT Activated
	FLASHING GREEN	Input Activated	Input Activated
	SOLID AMBER	OPEN Circuit	N/A
	SOLID RED	SHORT Circuit	N/A
	OFF	Input NOT configured in myQ Community.	

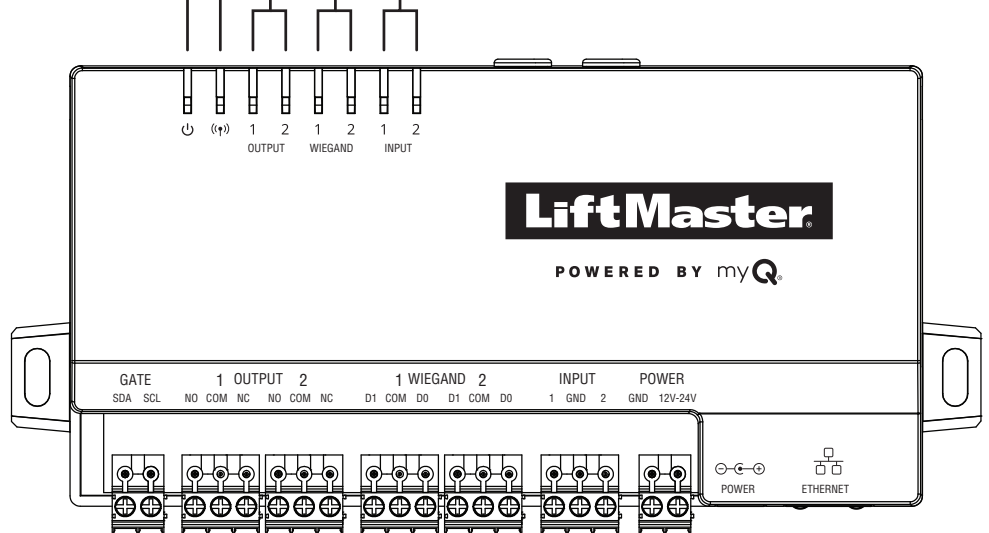

Wall Installation

1. Drill (2) pilot holes, spaced 7 in. (17.78 cm) apart, on the wall where the device will be mounted.
2. Use (2) #6 Phillips mounting screws (not included) to attach the device to the wall.

NOTE: For exterior mounting, LiftMaster recommends the use of a polycarbonate NEMA enclosure.

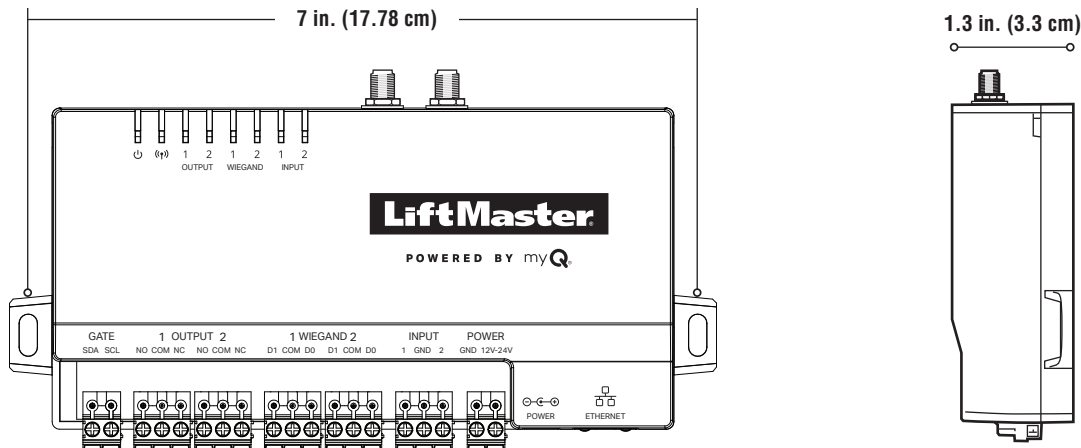

External Antenna Installation

For best cellular coverage position the antennas in the orientation shown below (perpendicular to each other).

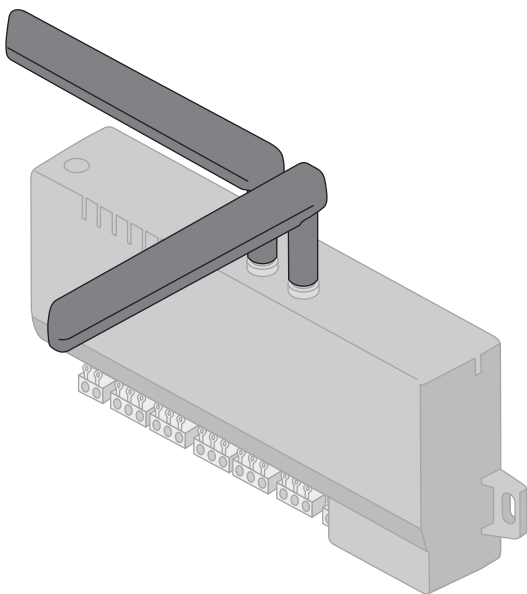

Connect Power

⚠️ ⚡ WARNING

To reduce the risk of SEVERE INJURY or DEATH:

- Disconnect power at the fuse box BEFORE proceeding.
- To AVOID damaging gas, power or other underground utility lines, contact underground utility locating companies BEFORE digging.
- ALL electrical connections MUST be made by a qualified individual.
- ALL power and control wiring MUST be run in separate conduit.
- ANY maintenance to the CAPAC or in the area near the CAPAC MUST NOT be performed until disconnecting the electrical power. Upon completion of maintenance the area MUST be cleared and secured, at that time the unit may be returned to service.
- CAPAC MUST be properly grounded and connected in accordance with national and local electrical codes. NOTE: The CAPAC should be on a separate fused line of adequate capacity.

- All power wiring should be on a dedicated circuit and well protected. The location of the power disconnect should be visible and clearly labeled.

To protect against fire and electrocution:

- Disconnect power BEFORE installing or servicing CAPAC.
- NEVER connect a keypad/reader or lock to doors without first consulting the applicable fire code.
- You MUST consult with, and get approval from, local fire officials BEFORE installing locks or devices on ANY doors that may be fire exits.
- Use of egress push buttons may not be legal. Single action exits may be required.
- ALWAYS obtain proper permits and approvals in writing BEFORE installing equipment.

Connect 12VDC (7.5 W minimum) power supply to the Power input connector.

OR

Connect power via power supply connector port.

NOTE: In UL installations the CAPAC shall be powered from the power limited output of a UL 294 Listed power supply, a UL 603 Listed power supply, a UL 294 Listed access control unit or a UL 325 gate operator.

⚠️ CAUTION

- DO NOT connect the power supply to a switched outlet or otherwise controlled AC outlet.
- DO NOT connect the power supply to the 120 Vac outlet until ALL wiring is completed.

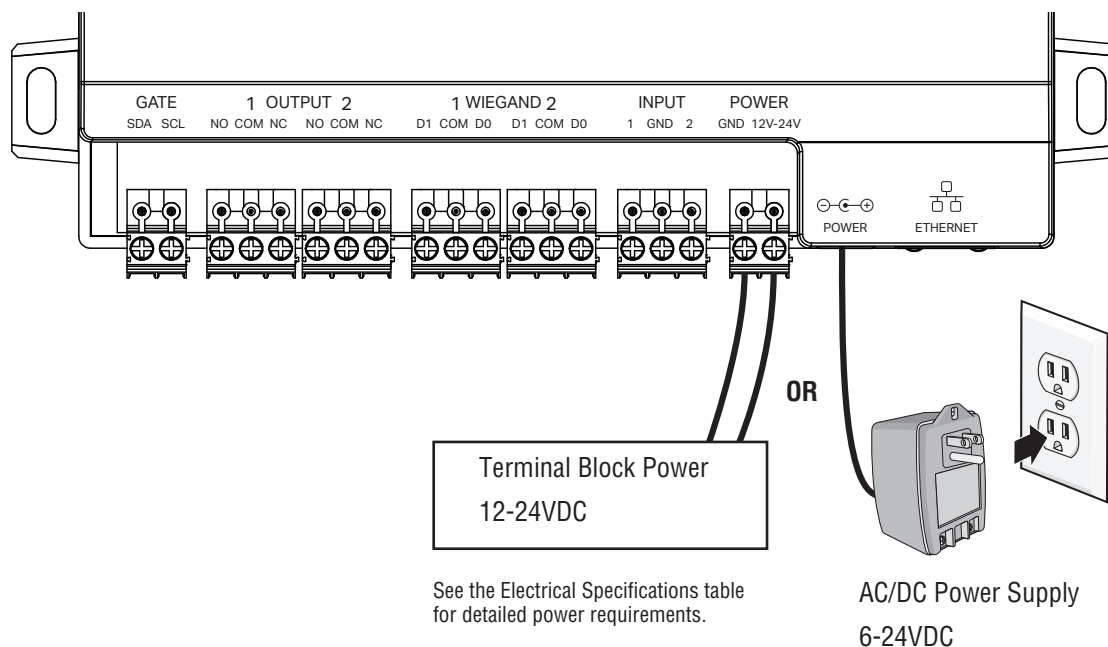

Gate Access

CAUTION

Not responsible for conflicts between the information listed in the wiring diagram and the requirements of your local building codes. The information is for suggested use ONLY. Check your local codes BEFORE installation.

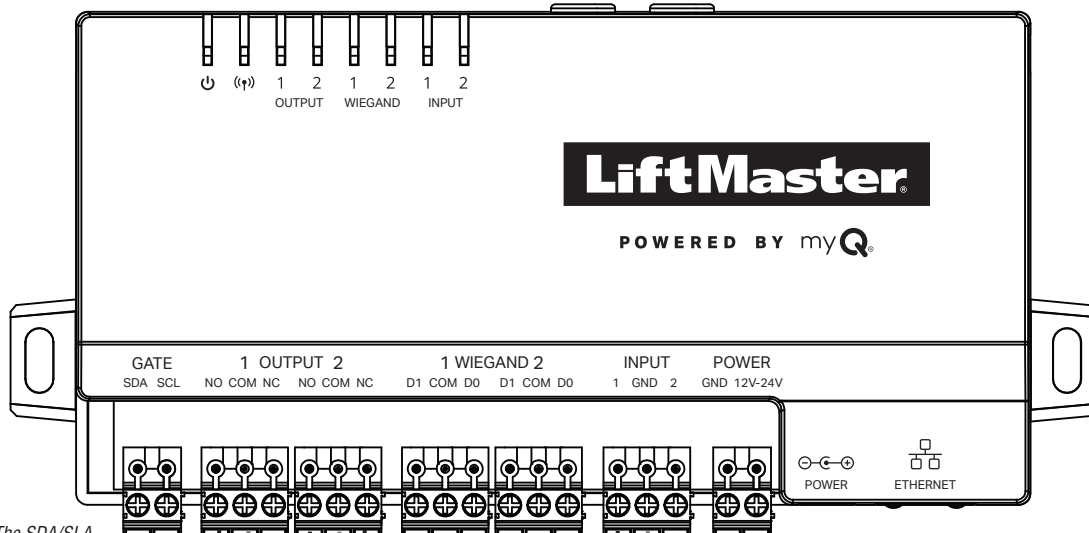

NOTE: The SDA/SLA Gate input/output shall not be connected in UL applications.

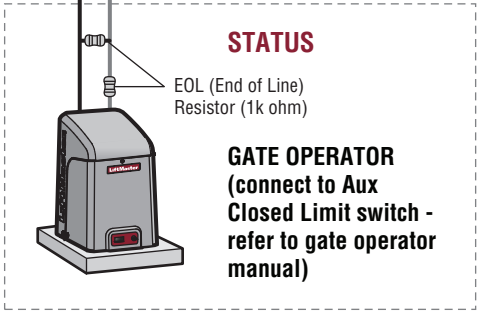

NOTE: The application displays a warning if the gate does not open or close.

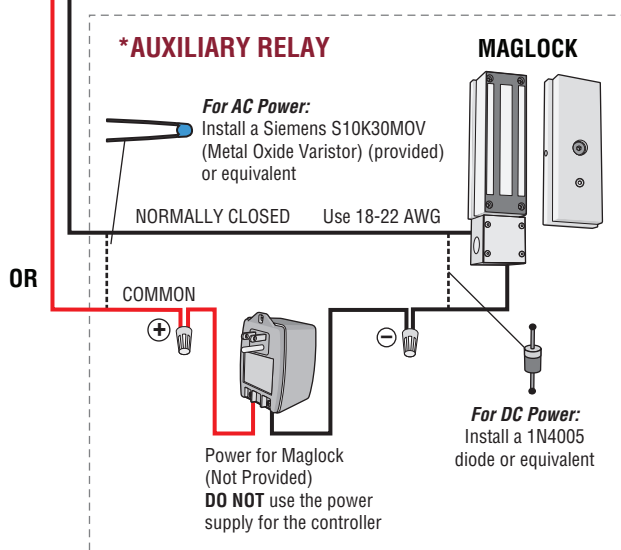
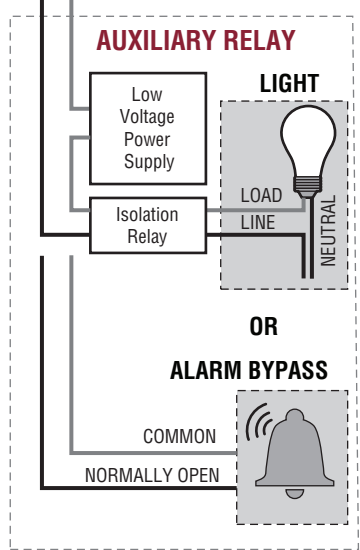
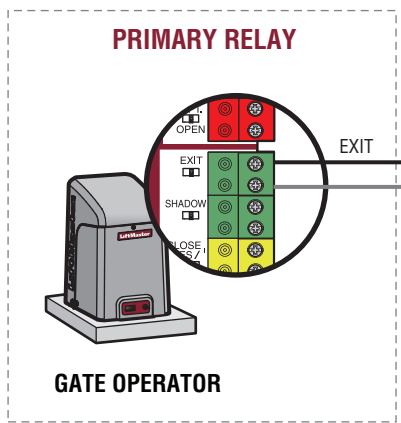

NOTE: For UL installations, only UL 325 Listed gate operators, UL 294 Listed electric door strikes or UL 294 Listed maglocks may be connected to relay output 1 or 2.

Door Access

⚠ WARNING

DO NOT INSTALL THE SYSTEM IN THE FAIL SECURE MODE UNLESS PERMITTED BY THE LOCAL AUTHORITY HAVING JURISDICTION. Doing so may cause interference with the operation of panic hardware.

⚠ CAUTION

Not responsible for conflicts between the information listed in the wiring diagram and the requirements of your local building codes. The information is for suggested use ONLY. Check your local codes BEFORE installation.

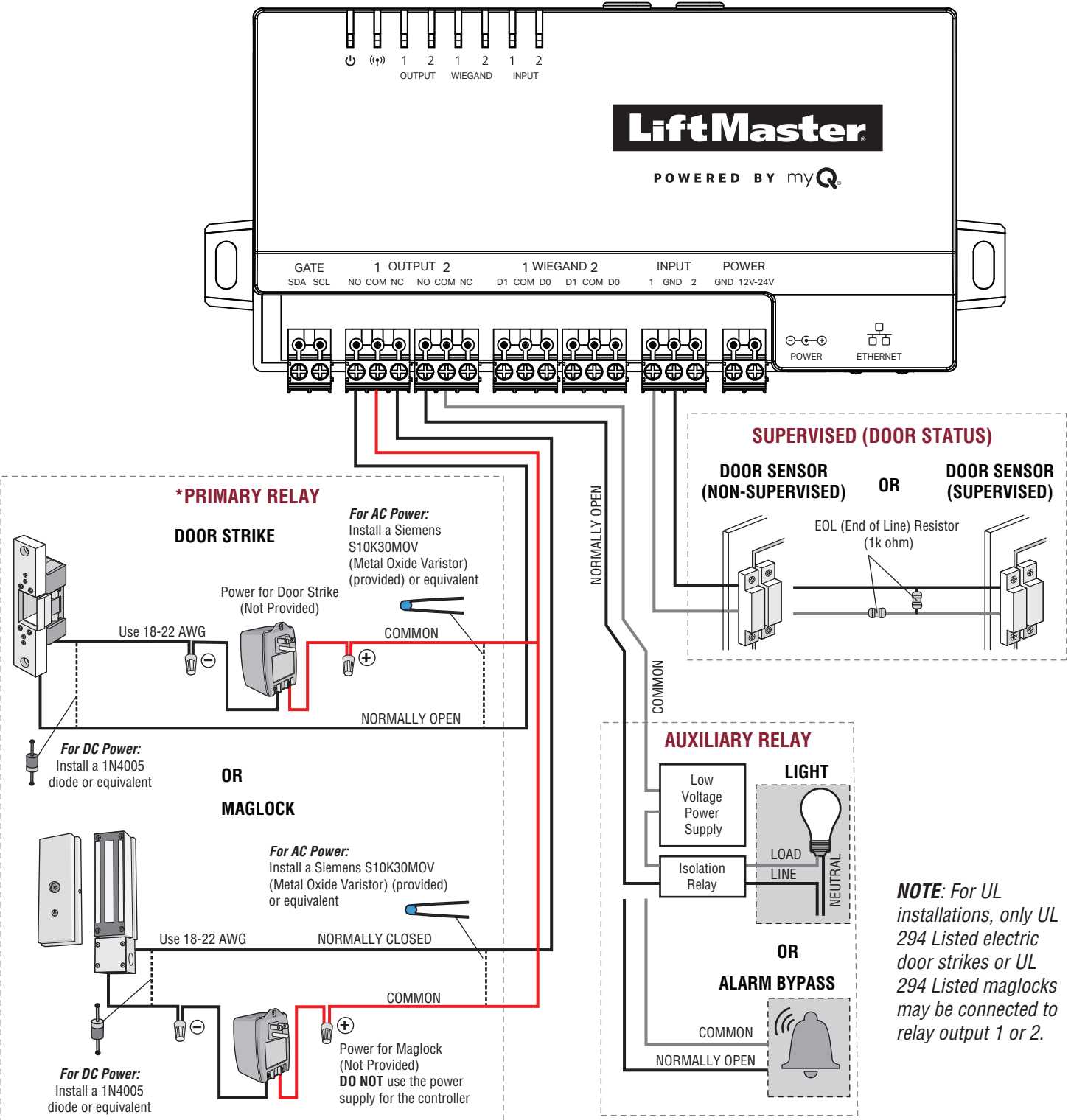

NOTE: For UL installations, only UL 294 Listed electric door strikes or UL 294 Listed maglocks may be connected to relay output 1 or 2.

Door Access - Vestibule

WARNING

DO NOT INSTALL THE SYSTEM IN THE FAIL SECURE MODE UNLESS PERMITTED BY THE LOCAL AUTHORITY HAVING JURISDICTION. Doing so may cause interference with the operation of panic hardware.

CAUTION

Not responsible for conflicts between the information listed in the wiring diagram and the requirements of your local building codes. The information is for suggested use ONLY. Check your local codes BEFORE installation.

NOTE: For UL installations, only UL 294 Listed electric door strikes or UL 294 Listed maglocks may be connected to relay output 1 or 2.

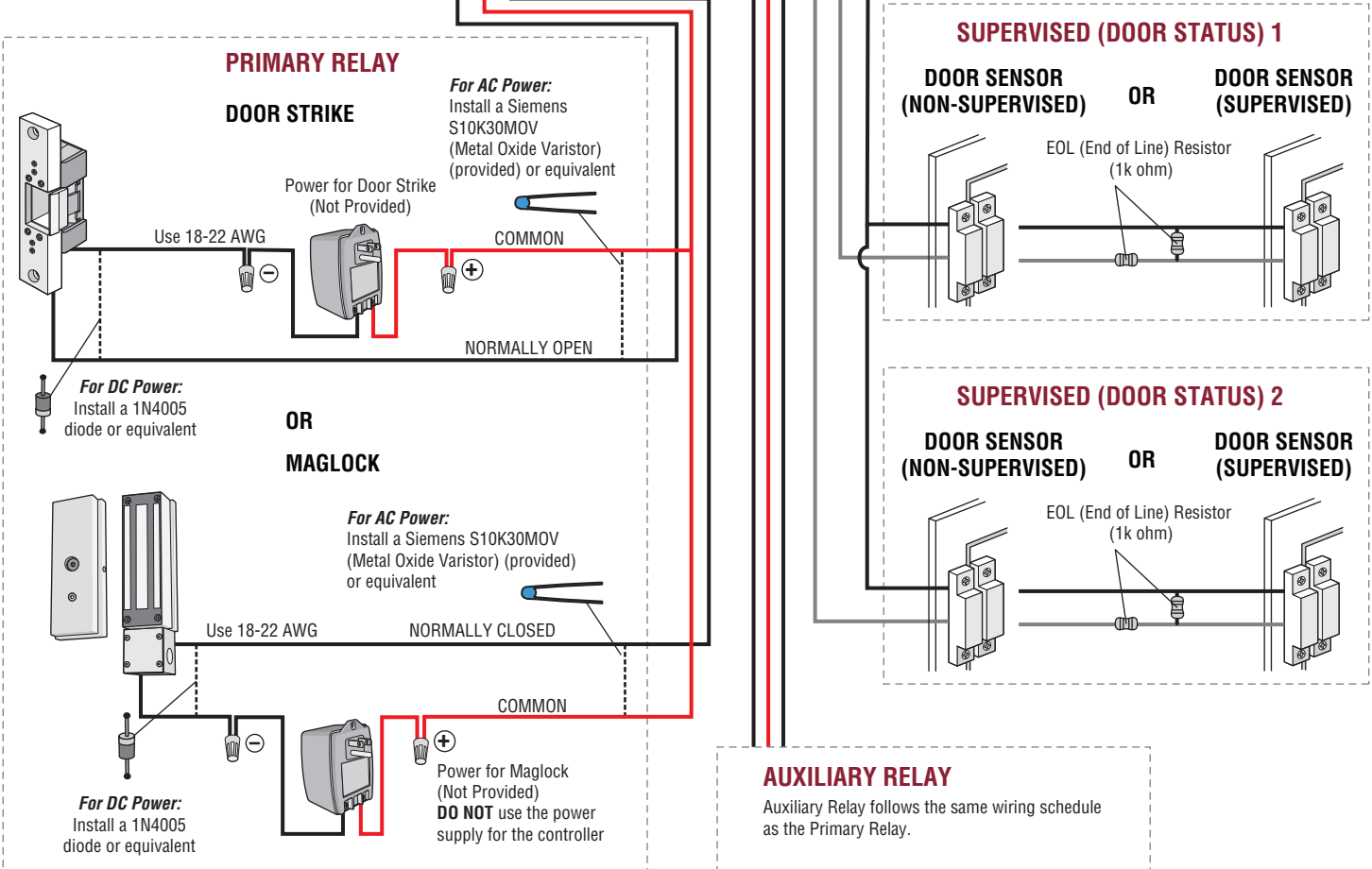
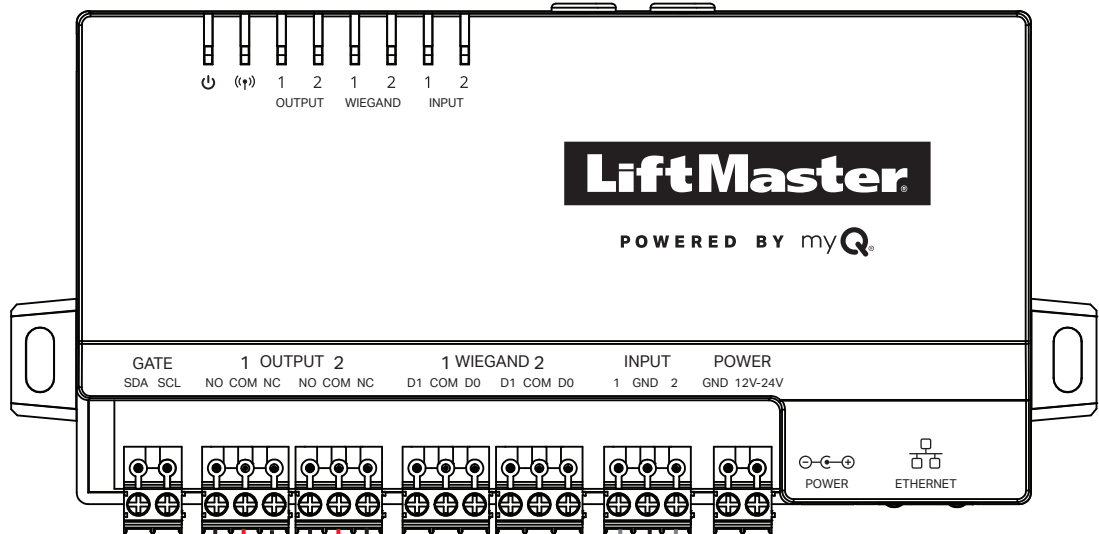

Wiegand Output

NOTE: Disconnect power **BEFORE** making electrical connections.

The CAPAC will send the pre-assigned credential, configured via myQ Business, to the TES via the Wiegand output.

⚠ CAUTION

Not responsible for conflicts between the information listed in the wiring diagram and the requirements of your local building codes. The information is for suggested use **ONLY**. Check your local codes **BEFORE** installation.

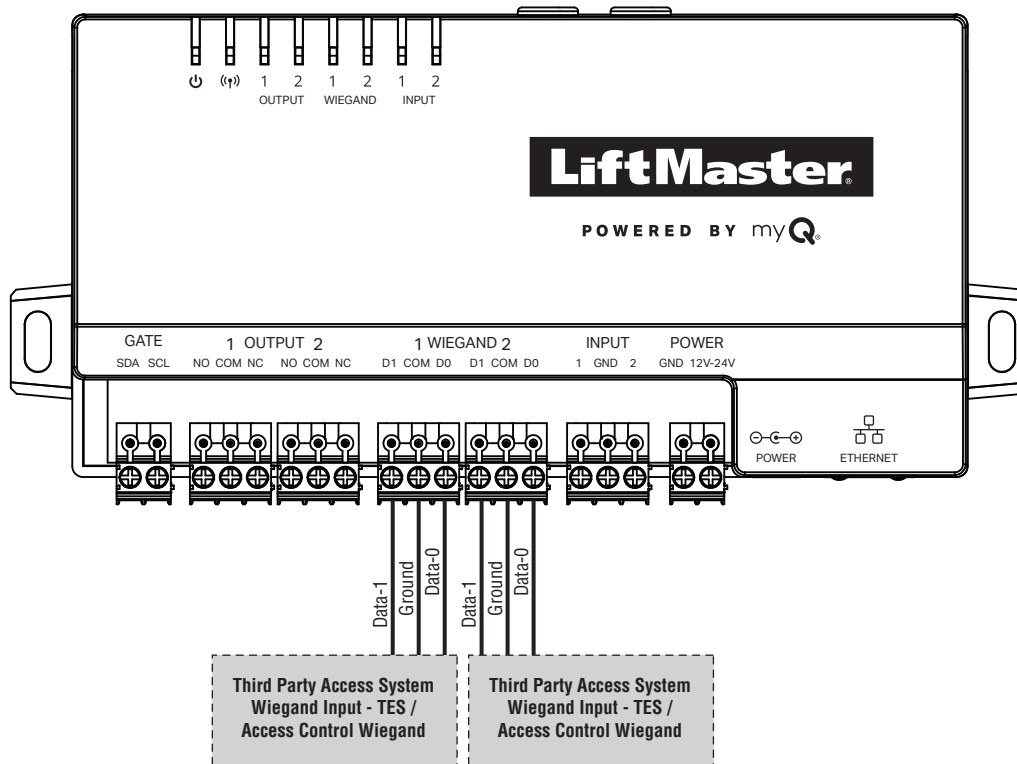

NOTE: For UL installations, only a Listed UL 294 access control unit may be connected to Wiegand output 1 or 2.

Repair Parts

ITEM	PART NUMBER
Antenna Replacement Kit	K41-0231-000

Accessories

ITEM	PART NUMBER
CAPAC External Cellular Antenna Kit	CELLXKT

Legal Disclaimers

Canada-Underwriters Laboratories Compliance

The CAPAC shall be installed in accordance with Part 1 of the Canadian Electrical Code.

Documentation Disclaimer and Restrictions

Information in this document is subject to change without notice and does not represent a commitment on the part of LiftMaster. For the most up-to-date information, visit LiftMaster.com.

This document and the data herein shall not be duplicated, used or disclosed to others for procurement or manufacturing, except as authorized with the written permission of LiftMaster. The information contained within this document or within the product itself is considered the exclusive property of LiftMaster. All information in this document or within the hardware and software product themselves is protected by the copyright and/or other intellectual property laws of the United States.

UL 294 Access Control Unit Endurance: Level 3, Line security: Level 1, Destructive Attack: Level 1, Power Standby: Level 1

NOTICE: This device complies with part 15 of the FCC rules and Innovation, Science and Economic Development Canada license-exempt RSSs. Operation is subject to the following two conditions: (1) this device may not cause harmful interference, and (2) this device must accept any interference received, including interference that may cause undesired operation. Any changes or modifications not expressly approved by the party responsible for compliance could void the user's authority to operate the equipment.

This device must be installed to ensure a minimum 20 cm (8 in.) distance is maintained between users/bystanders and device.

This device has been tested and found to comply with the limits for a Class B digital device, pursuant to part 15 of the FCC rules and Industry Canada ICES standard. These limits are designed to provide reasonable protection against harmful interference in a residential installation. This equipment generates, uses and can radiate radio frequency energy and, if not installed and used in accordance with the instructions, may cause harmful interference to radio communications.

However, there is no guarantee that interference will not occur in a particular installation. If this equipment does cause harmful interference to radio or television reception, which can be determined by turning the equipment off and on, the user is encouraged to try to correct the interference by one or more of the following measures:

- Reorient or relocate the receiving antenna.
- Increase the separation between the equipment and receiver.
- Connect the equipment into an outlet on a circuit different from that to which the receiver is connected.
- Consult the dealer or an experienced radio/TV technician for help.

NOTE: When installing CAPAC, please refer to the local jurisdiction for any specific requirements such as physical signage that may be required.

Warranty

LiftMaster (“Seller”) warrants to the first purchaser of this product, for the structure in which this product is originally installed, that it is free from defect in materials and/or workmanship for a period of two years from the date of purchase.

The proper operation of this product is dependent on your compliance with the instructions regarding installation, operation, maintenance and testing. Failure to comply strictly with those instructions will void this limited warranty in its entirety.

If, during the limited warranty period, this product appears to contain a defect covered by this limited warranty, call 1-800-528-2806 before dismantling this product. Then send this product, pre-paid and insured, to our service center for warranty replacement. Products returned to Seller for warranty replacement, which upon receipt by Seller are confirmed to be defective and covered by this limited warranty, will be replaced (at Seller’s sole option) at no cost to you and returned pre-paid. Defective parts will be replaced with new or factory-rebuilt parts at Seller’s sole option.

THIS LIMITED WARRANTY IS IN LIEU OF ANY OTHER WARRANTIES, EXPRESS OR IMPLIED, INCLUDING ANY IMPLIED WARRANTY OF MERCHANTABILITY OR FITNESS FOR A PARTICULAR PURPOSE OR OTHERWISE, AND OF ANY OTHER OBLIGATIONS OR LIABILITY ON SELLER’S PART. THIS LIMITED WARRANTY DOES NOT COVER NON-DEFECT DAMAGE, DAMAGE CAUSED BY IMPROPER INSTALLATION, OPERATION OR CARE (INCLUDING, BUT NOT LIMITED TO ABUSE, MISUSE, FAILURE TO PROVIDE REASONABLE AND NECESSARY MAINTENANCE, UNAUTHORIZED REPAIRS OR ANY ALTERATIONS TO THIS PRODUCT), LABOR CHARGES FOR REINSTALLING A REPAIRED OR REPLACED UNIT, PROBLEMS RELATED TO INTERFERENCE, OR REPLACEMENT OF BATTERIES.

UNDER NO CIRCUMSTANCES SHALL SELLER BE LIABLE FOR CONSEQUENTIAL, INCIDENTAL OR SPECIAL DAMAGES ARISING IN CONNECTION WITH USE, OR INABILITY TO USE, THIS PRODUCT. IN NO EVENT SHALL SELLER’S LIABILITY FOR BREACH OF WARRANTY, BREACH OF CONTRACT, NEGLIGENCE OR STRICT LIABILITY EXCEED THE COST OF THE PRODUCT COVERED HEREBY. NO PERSON IS AUTHORIZED TO ASSUME FOR US ANY OTHER LIABILITY IN CONNECTION WITH THE SALE OF THIS PRODUCT.

Some states do not allow the exclusion or limitation of consequential, incidental or special damages, so the above limitation or exclusion may not apply to you. This limited warranty gives you specific legal rights, and you may also have other rights which vary from state to state.

HOW TO ORDER REPAIR PARTS

DEVANCO  **CANADA**

19192 HAY ROAD, UNIT Q
SUMMERSTOWN, ON, K0C 2E0

TOLL FREE **1-855-931-3334**
WWW.DEVANCOCANADA.COM

**WHEN ORDERING REPAIR PARTS
PLEASE SUPPLY THE FOLLOWING INFORMATION:**

- ✓ **PART NUMBER**
- ✓ **DESCRIPTION**
- ✓ **MODEL NUMBER**